

Compressor pack

Installation and operation manual



	Page
Introduction, scope, disclaimer	3
Safety information	4
Features & benefits	6
Pack layout	7
Pack schematic	8
Components description	8
Bill of materials	9
Compressor pack operation logic	12
Inspection	12
Electrical schematic diagram	13
Next gen CoreSense	20
Overall dimension & weight, storage guidelines	29
Installation & commissioning	29
Compressor pack error codes	33
Commissioning report	34

Introduction

Copeland multi compressor pack comes with state of art semi-hermetic stream compressors equipped with discus valve technology and CoreSense diagnostics. Compressor packs are available in 3,4 & 5 compressors options with maximum capacity of 200 HP for low temperature and 250 HP for medium temperature applications.

This document is designed to help the contractor and customer for the installation, commissioning & operation of Copeland's multi compressor pack.

Scope - compressor packs are supplied without condenser. Suitable capacity air / water cooler condenser to be connected to the Compressor Pack. Liquid receiver is optional and could be supplied along with the compressor pack. Please check the detailed scope from page 9 of this manual.

Disclaimer

Thank you for purchasing the Copeland compressor pack. We hope that this product meets your refrigeration needs. Please read through this operation manual to familiarize yourself with the installation, commissioning and operation of this product. Please do read the following information in this page before proceeding with the rest of the manual.

The Copeland compressor pack should only be installed by suitably qualified and experienced refrigeration technicians. No responsibility can be accepted for damage caused by inexperienced or inadequately trained site technicians or improper system design. All instructions and procedures described in this manual are based on good refrigeration trade practices as applicable to this particular product. The installation contractor may prefer to use variations to these recommendations. However, the methods described in this manual represent the minimum requirements to avoid any subsequent warranty claims for this equipment and its components. These instructions do not cover the fundamentals of good electrical or refrigeration practice and are therefore intended for use only by qualified and/or experienced personnel or technicians.

Please consult your local sales office, quoting unit model and serial number as shown on the nameplate. In case of ambiguity, the wiring diagram supplied with each unit takes precedence over the diagram in this manual.

1. Safety Information







1.1

Installation and commissioning work on compressor pack shall be carried out only by qualified, accredited refrigeration personnel who have been trained and instructed.

1.2

Compressor pack is manufactured according to the latest safety standards. Emphasis has been placed on the user's safety. For relevant standards please refer to the manufacturer's declaration, available on request. These instructions should be retained throughout the lifetime of the compressor pack. You are strongly advised to follow these safety instructions.

1.3 Icon explanation

 WARNING This icon indicates instructions to avoid personal injury and material damage.	 CAUTION This icon indicates instructions to avoid property damage and possible personal injury.
 HIGH VOLTAGE This icon indicates operations with a danger of electric shock.	 IMPORTANT This icon indicates instructions to avoid malfunction of the compressor.
 DANGER OF BURNING OR FROSTBITE This icon indicates operations with a danger of burning or frostbite.	NOTE This word indicates a recommendation for easier operation.
 EXPLOSION HAZARD This icon indicates instructions operations with a danger of explosion.	

2.4 Safety statements

- a. Only qualified and authorized refrigeration personnel are permitted to install, commission and maintain this equipment.
- b. Electrical connections must be made by qualified electrical personnel.
- c. All valid standards for connecting electrical and refrigeration equipment must be observed.
- d. The national legislation and regulations regarding personnel protection must be observed.



Use personal safety equipment. Safety goggles, gloves, protective clothing, safety boots and hard hats should be worn where necessary.

2.5 General instructions

Warning



System breakdown! Personal injuries! Never install a system in the field and leave it unattended when it has no charge, a holding charge, or with the service valves closed without electrically locking out the system.

System breakdown! Personal injuries! Only approved refrigerants and refrigeration oils must be used.

Warning



High shell temperature! Burning! Do not touch the compressor until it has cooled down. Ensure that other materials in the area of the compressor do not get in touch with it. Lock and mark accessible sections.

Caution



Overheating! Bearing damage! Do not operate compressors without refrigerant charge or without being connected to the system.

Caution



Compressors contain oil & refrigerant under pressure. Release pressure from both high & low side of compressor before servicing.

Caution



Tube brazing & compressor operation can produce hot surfaces. To avoid burns, allow surfaces to cool.

2.6 Safety refrigerants/lubricant

- a. Refer name plate details for the use of correct refrigerant, generally it is R404A.
- b. Compressor Pack are supplied with an initial oil charge. The standard oil charge for use with refrigerant R404A is polyolester (POE) lubricant Emkarate RL 32 3MAF.

3. Features and benefits

Features	Benefits
Stream semi-hermetic compressor with CoreSense diagnostics	<ul style="list-style-type: none"> - Stream's unique discus valve technology makes it more efficient than other equivalent compressor and therefore helps reduce the carbon footprint and running cost of any installation. - Stream is a multi-refrigerant compressor. One model suits all applications without any compromise on performance. - CoreSense diagnostics offers advanced protection and diagnostics benefits for excellent system reliability, reduced service costs and increased equipment uptime. - Stream range provides best in class performance for today's commonly used HFCs and future low GWP refrigerants. This results in significantly lower cost of operation and reduced environmental impact compared to competing products.
Copeland iProRack controller	<ul style="list-style-type: none"> - Optimized algorithms for efficient compressor pack control. - Flexible and easy to configure. - Large and easy to read display.
Electrical panel	<ul style="list-style-type: none"> - Circuit breakers, thermal overload protection provided for individual compressors and condenser fans. Phase failure and voltage protection for reliable operation.
Copeland electronic oil management system	<ul style="list-style-type: none"> - Active oil management with Copeland branded oil separator, oil receiver, oil filter, oil pressure switch and electronic oil level regulator ensures proper oil return to protect the compressor
Copeland pack frame and layout	<ul style="list-style-type: none"> - Robust & sturdy frame with mounting reduces noise and vibration. - Pack layout facilitates serviceability.
Liquid station / receiver (optional)	<ul style="list-style-type: none"> - Allows flexibility when installing liquid receiver either side by side to the pack or close to the condenser or evaporators. Both horizontal and vertical receiver options are available.

4. Layout: compressor pack

Item	Description	Item	Description
1	Base - frame	13	Control panel
2	Stream compressor	14	Discharge line to condenser
3	Discharge lines with check valve	15	Check valve
4	Oil return line ball valve	16	Oil separator
5	Oil return header	17	Suction return line
6	Electronic oil level control (OM3)	18	Suction ball valve
7	Pressure control switch	19	LP transducer
8	Oil sight glass	20	HP transducer
9	Oil return line main ball valve	21	Suction header
10	Oil filter	22	Discharge header
11	Oil reservoir	23	Suction filter-ball valve
12	Differential pressure valve	24	Suction filter

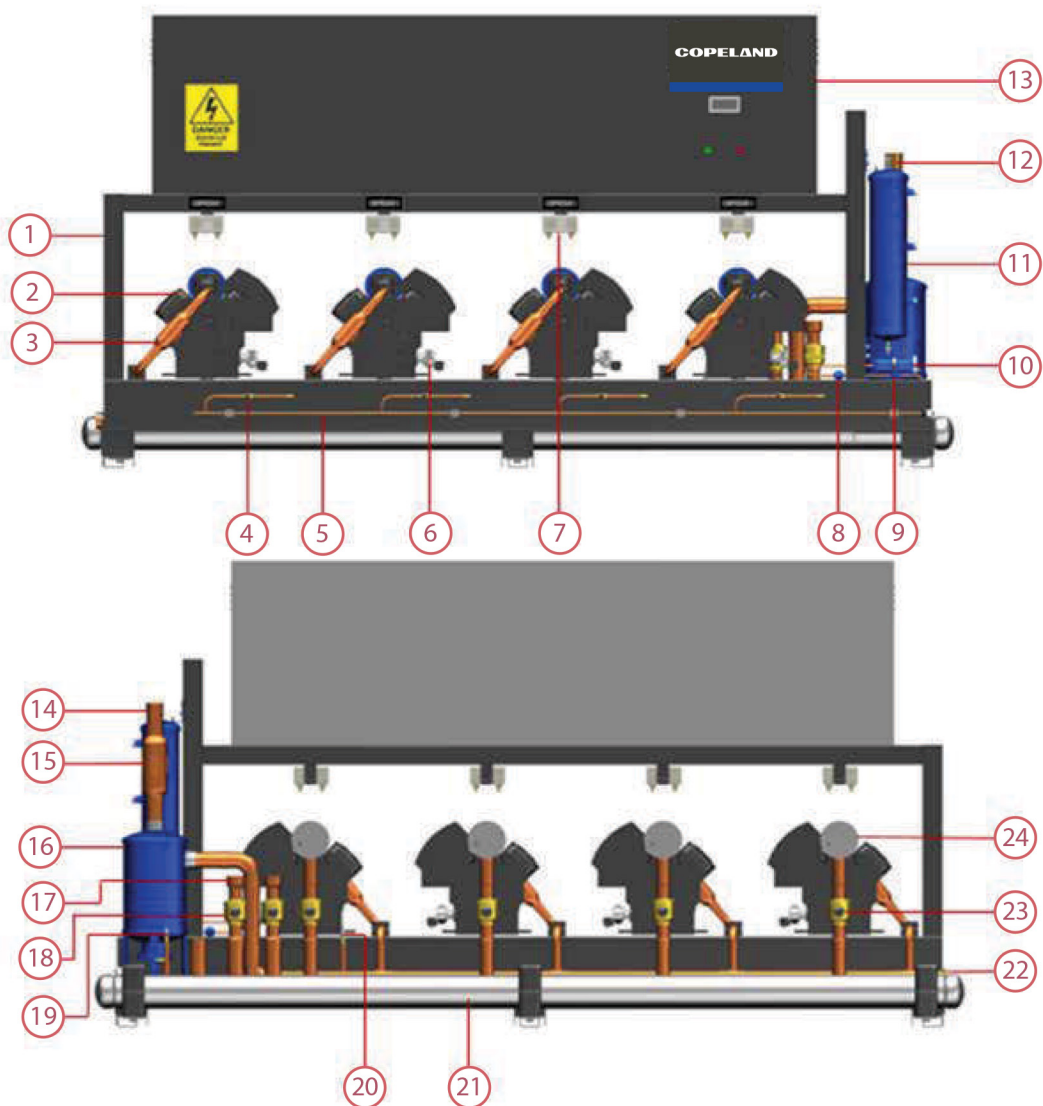

Receiver / liquid station (optional)

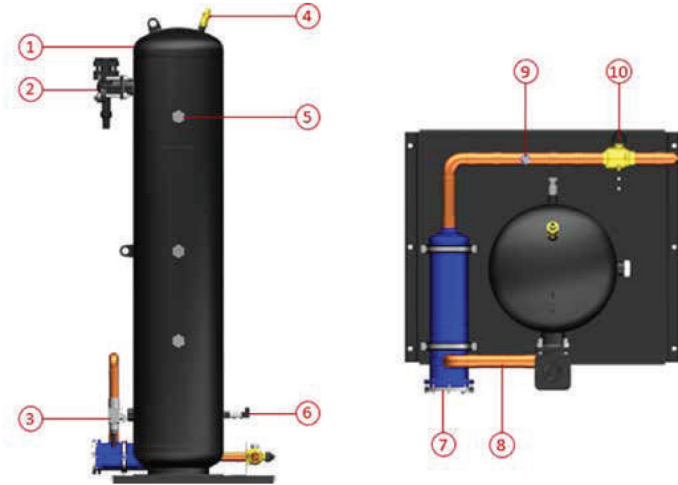

Item	Description
1	Receiver
2	Inlet valve
3	Outlet valve
4	Pressure relief valve
5	Receiver sight glasses
6	Liquid level switch
7	Filter drier
8	Liquid line
9	Liquid line sight glass
10	Ball valve

5. Schematic diagram - 4 compressor pack

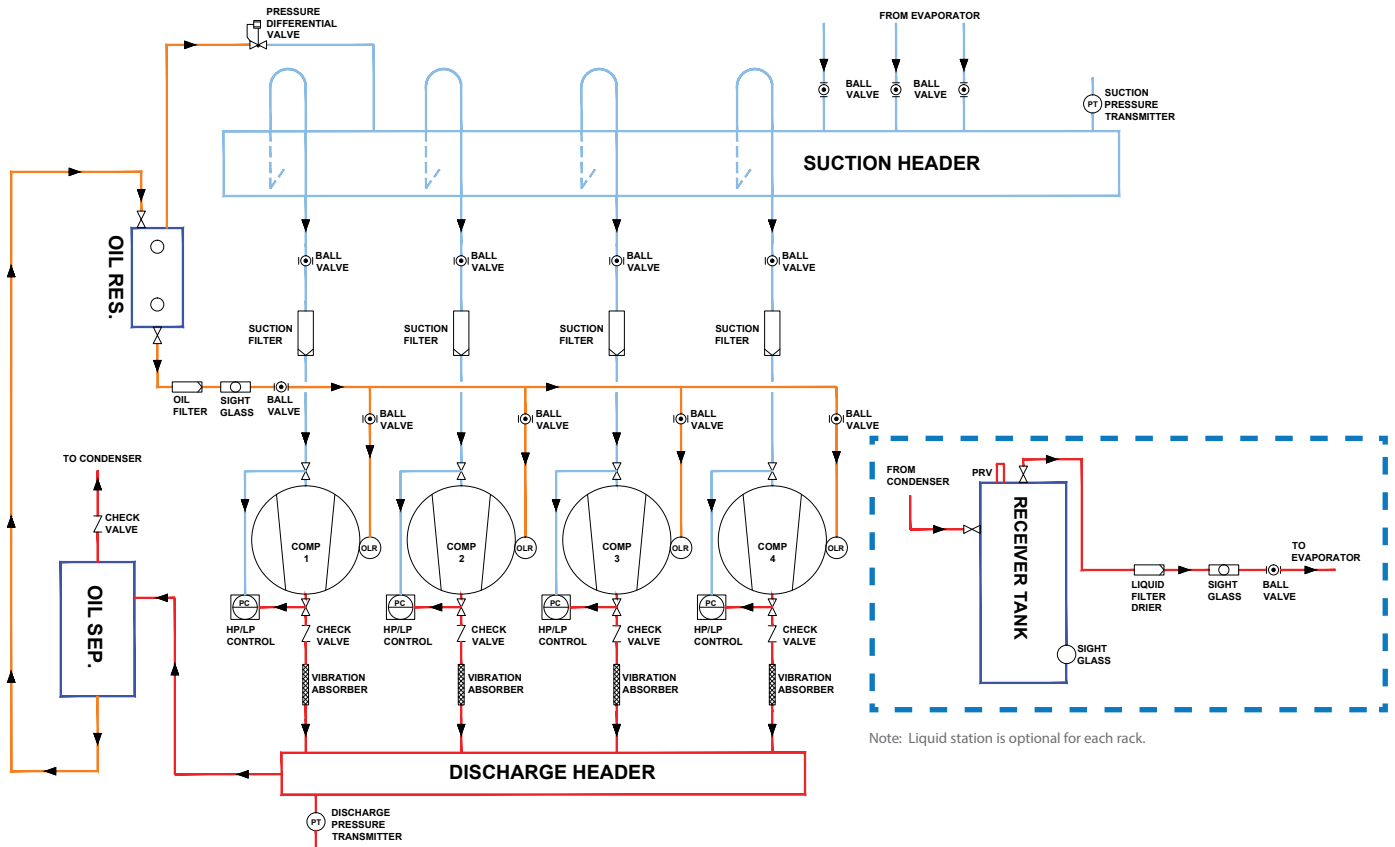

6. Standard bill of materials

a. Compressors

Copeland Stream compressors with CoreSense protection module

b. Line components

- Ball valves
- Check valves (Individual compressor discharge line and oil separator outlet)
- High pressure/low pressure adjustable cut-outs
- HP transducer (Copeland PP/PPR series)
- LP transducer (Copeland PP/PPR series)
- Pressure relief valve (on receiver)
- Suction line filter drier (replaceable core type)

c. Optimized and insulated suction header

The suction headers are designed for the lowest pressure loss and at the same time sufficiently return oil back to the compressor. The suction header is designed with high quality refrigerant grade material.

d. High quality discharge header

The discharge headers are designed for field reliability to handle the start stop stresses and discharge pulsation. The discharge header is designed with high quality refrigerant grade material.

e. Compressor pack frame

The frames are built with mild steel and painted for strength and rust prevention. The frame is supported by mountings to absorb the transmitted vibration.

f. Optional liquid station

It consists of:

- Liquid receiver with service valves and built-in sight glass (2 or 3)
- Filter drier with replaceable core
- Moisture indicator
- Liquid line ball valve
- Low liquid level alarm switch
- Pressure relief valve

The separate liquid station allows for flexible installation of liquid receiver either side by side to the pack or close to the condenser or evaporators.

g. Copeland iProRack controller

Copeland multi-compressor packs are designed with Copeland iProRack controller. The software is created on a well-structured and documented development system. This provides guaranteed controller support throughout the equipment lifetime. It can control up to two circuits with a maximum of six compressors per circuit. iProRack provides benefits to end users and contractors that are simply unmatched by any multiple controller platform in the market today.

iProRack controller is interfaced with a visograph, featuring a LCD graphic display. This provides excellent interface on the machine room to view stream compressor operation status, modulation, CoreSense diagnostics messages, and other operating information. iProRack controller communicates with the CoreSense diagnostics module for maximum compressor protection against low oil pressure, excessive discharge temperature and motor overheat.

h. Control panel

Copeland multi-compressor packs are fitted with a fully featured electrical panel for ease of installation and reduced field cost. The panel uses high quality electrical switch gears and cables. It is designed for high reliability and safe operation.



Features of the electrical panel include:

- Flexible and easy to configure circuit breakers and thermal overload protectors for each individual compressor and condenser fans
- Phase failure & voltage protection
- Complete wiring for compressor pack control & management

i. Electronic oil management system

Below figure shows a typical active electronic oil management system.

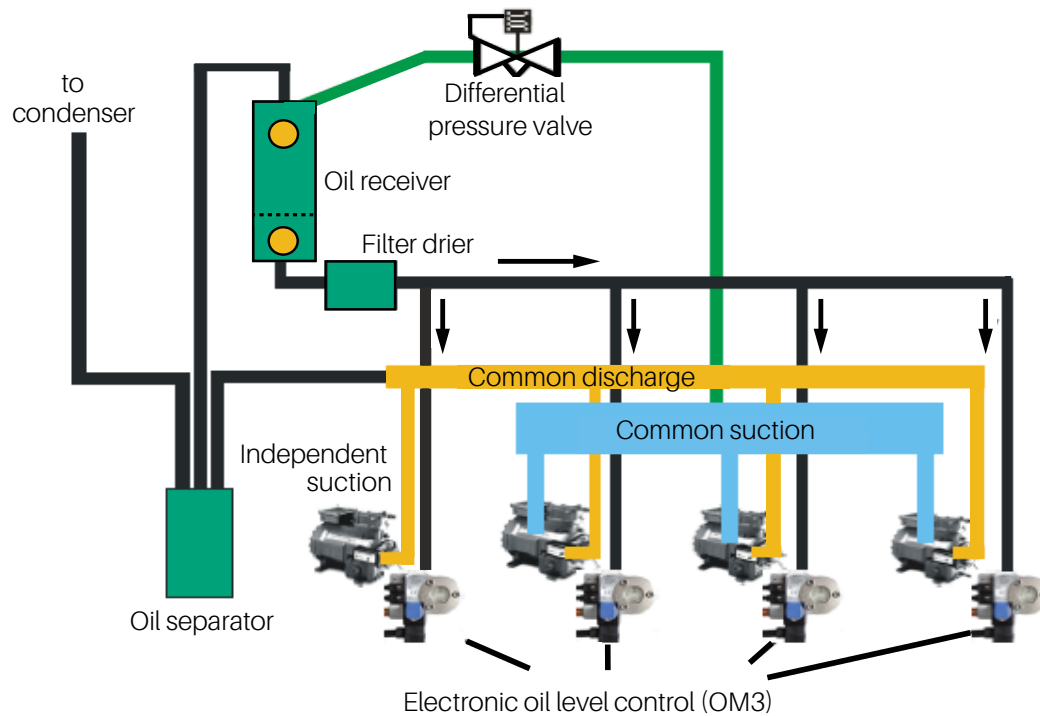

Oil management is an important parameter for any pack. As two or more compressors are operated in parallel, it is important that oil is circulated into the system and returned back to the compressors properly. If oil does not return properly to each compressor, it might lead to lubrication issues.

- Compressor capacity control (optional)
- Liquid station (optional):
 - Inlet and outlet service valve
 - Replaceable core filter
 - Moisture indicator
 - Pressure relief valve
 - Low liquid level alarm switch

7. Pack operation logic

iProRack controller functions to manage both compressors and condenser fans in a multi-compressor pack. Compressors can be simple, multistage or with inverters. Control is done with neutral zone or proportional band and is based on the pressure or temperature sensed in the LP suction (compressors) and HP (condenser) circuits. A special algorithm balances the run hours of the compressors to distribute the workload uniformly.

The front panel offers complete information on the system's status by displaying the suction and condenser pressure (temperatures), the status of the loads, possible alarms or maintenance conditions.

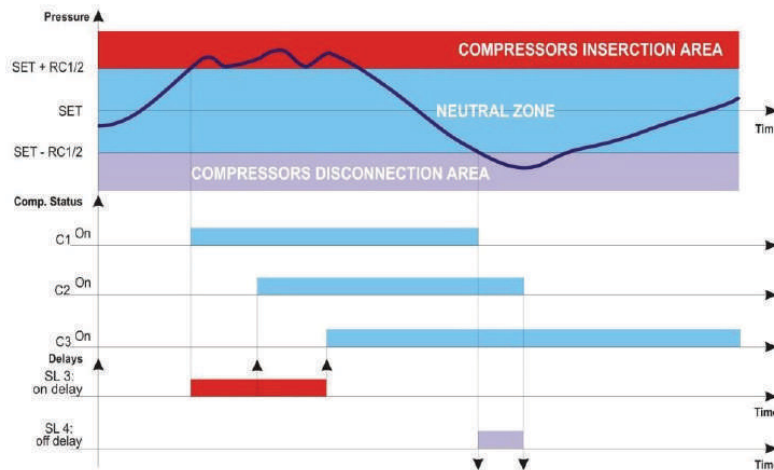

8. Inspection

Inspect the compressor pack and any accessories shipped with them for damages or shortages before and during unloading. All items on bill of lading should be accounted for prior to signing the shipping receipt. Note any shortages or damage on delivery receipt (specify the extent and type of damage found). Unit should be inspected carefully for concealed damage. Notify Copeland sales/application personnel of the damage immediately. Request an immediate joint inspection and do not repair the unit until inspected by Copeland's representative.

The system is shipped with a holding charge of dry nitrogen. Check to see that pressure is still in the unit upon receipt. Report lack of pressure immediately to the Copeland's application/sales representative.

9. Electrical schematics

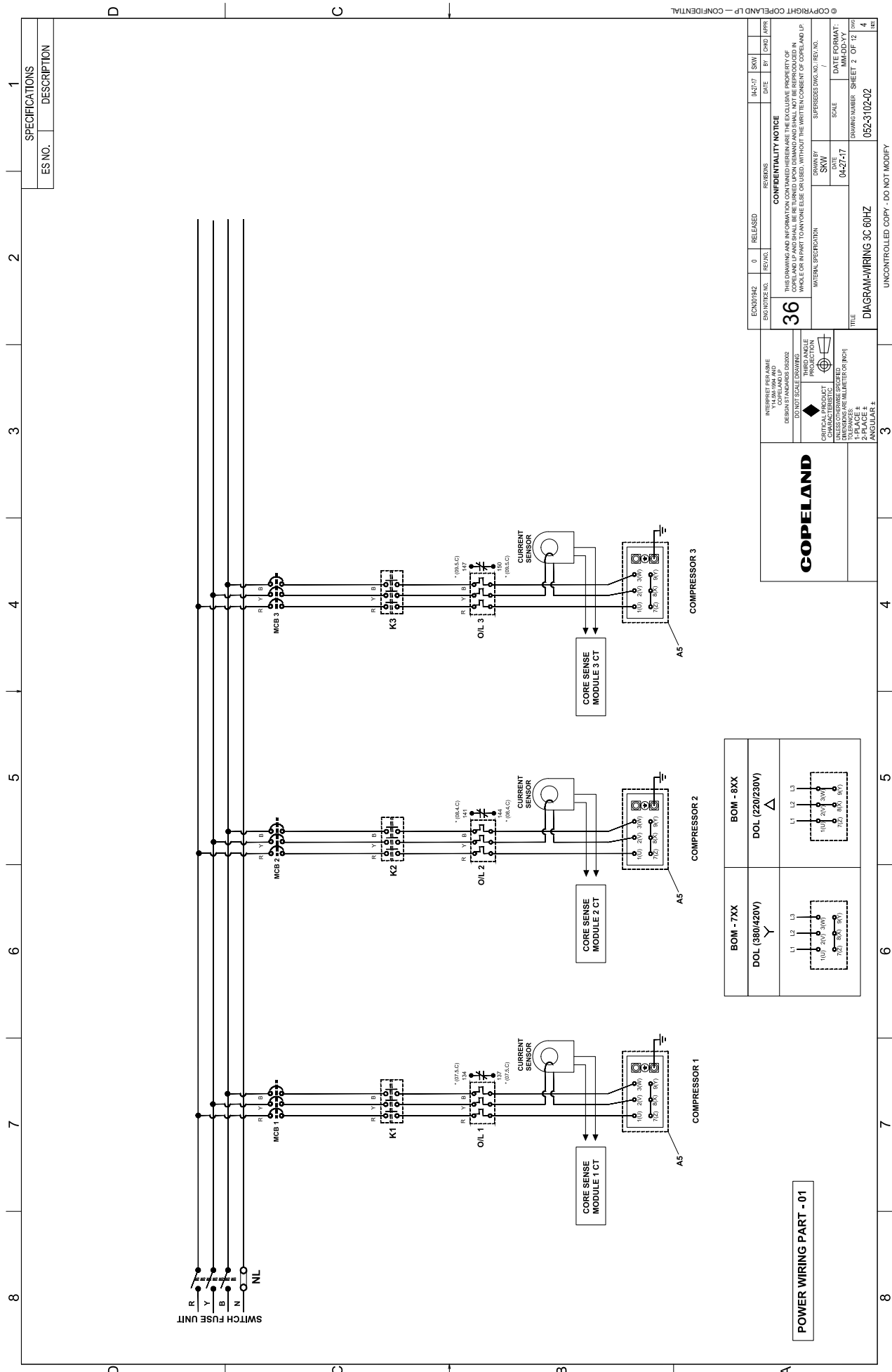

SPECIFICATIONS	
ES NO.	DESCRIPTION

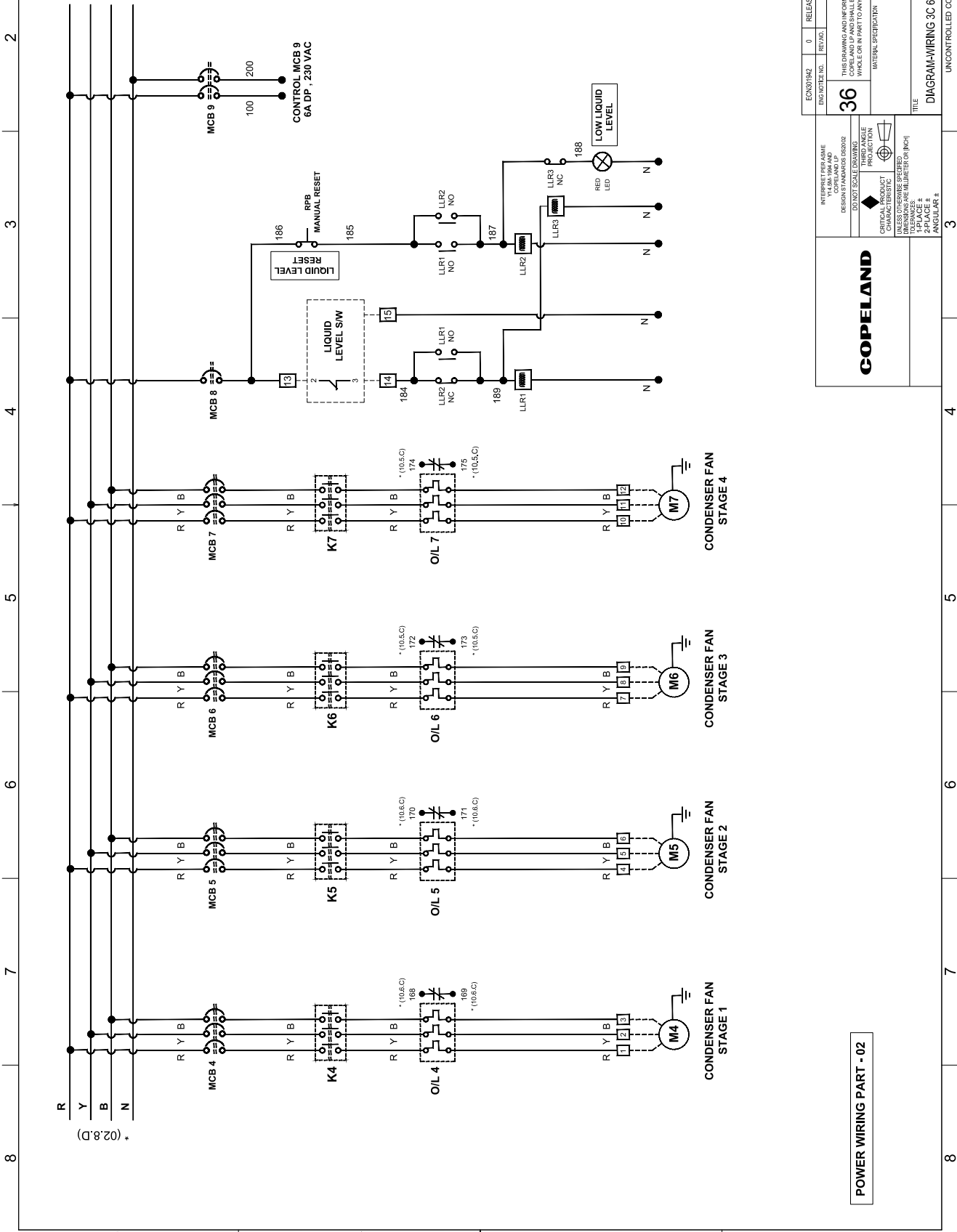

POWER WIRING PART -02

COPELAND

INVENTOR: JAMES COPPELAND LP
 DESIGNER: JAMES COPPELAND LP
 DOT/DOT SCALE DRAWING
 THIRD ANGLE PROJECTION
 CRITICAL PRODUCT DIMENSIONS ARE NUMERICAL OR [INCH] UNLESS OTHERWISE SPECIFIED
 UNLESS OTHERWISE SPECIFIED

CONFIDENTIALITY NOTICE
 THIS DRAWING AND INFORMATION CONTAINED HEREIN IS THE PROPERTY OF COPPELAND LP AND SHALL BE RETURNED UPON DEMAND AND SHALL NOT BE REPRODUCED IN WHOLE OR IN PART TO ANYONE ELSE OR USED WITHOUT THE WRITTEN CONSENT OF COPPELAND LP.
 MATERIAL SPECIFICATION
 DRAWN BY: SKW
 DATE: 04/27/17
 SCALE: /
 DATE FORMAT: MM.DD.YY
 DRAWING NUMBER: 052-3102-02
 SHEET: 3P 12
 TOTAL SHEETS: 4

ECONOMIZER: 0
 REVISED: /
 RELEASED: /
 REVISION: /
 ACT'D: SKW
 DATE: /
 DESIGNED: APR

UNCONTROLLED COPY - DO NOT MODIFY

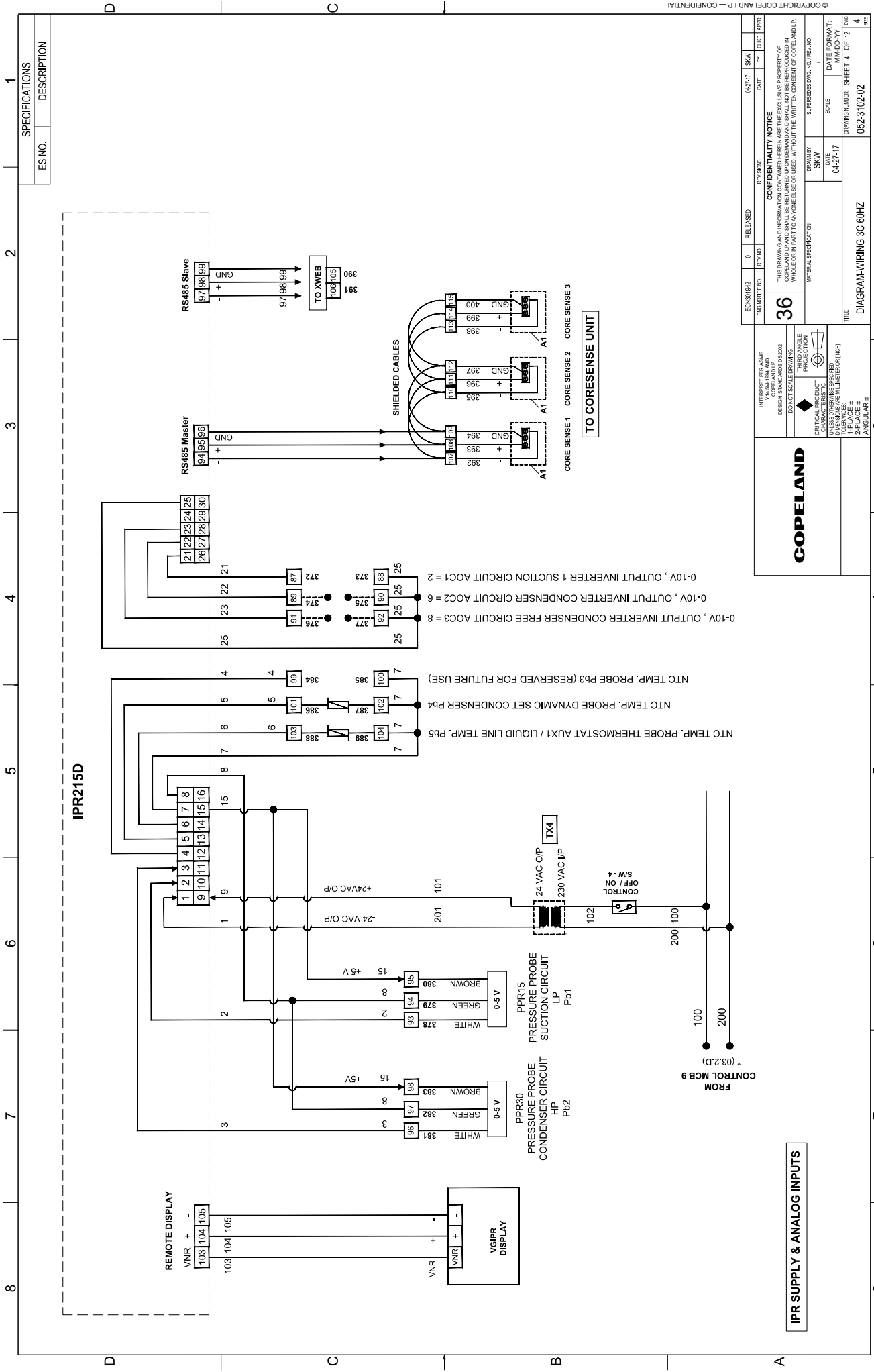

SPECIFICATIONS	
ES NO.	DESCRIPTION
1	

REV. NO.	RELEASED	ENGINTEER	REV. NO.	DATE	BY	CHKD	APPR
0				04-27-17	SKW		

36

CONFIDENTIALITY NOTICE
THIS DRAWING AND INFORMATION CONTAINED HEREIN ARE THE EXCLUSIVE PROPERTY OF COPPELAND LP AND SHALL BE RETURNED UPON DEMAND AND SHALL NOT BE REPRODUCED IN WHOLE OR PART IN ANY FORM OR BY ANY MEANS, WITHOUT THE WRITTEN CONSENT OF COPPELAND LP.

MATERIAL SPECIFICATION

DRAWN BY: SKW
SCALE: 1:1
SUPERSEDES DWG. NO. / REV. NO.:
DATE FORMAT: MM-DD-YY
DRAWN NUMBER: SHEET 4 OF 12
TITLE: DIAGRAM-WIRING 3C 60HZ
052-3102-02

COPPELAND

INTERNET WEB PAGE: www.copeland.com
Y14.6M 1000 AND DESIGN STANDARDS D35002
DO NOT SCALE DRAWING

THIRD ANGLE PROJECTION
UNLESS OTHERWISE SPECIFIED, DIMENSIONS ARE IN MILLIMETERS (OR INCHES) AND TOLERANCES ARE AS FOLLOWS:
DIMENSIONAL TOLERANCES:
HOLE: ±0.15
ANGULAR: ±0.5

IPR SUPPLY & ANALOG INPUTS

UNCONTROLLED COPY - DO NOT MODIFY

ES NO.	DESCRIPTION
1	SPECIFICATIONS

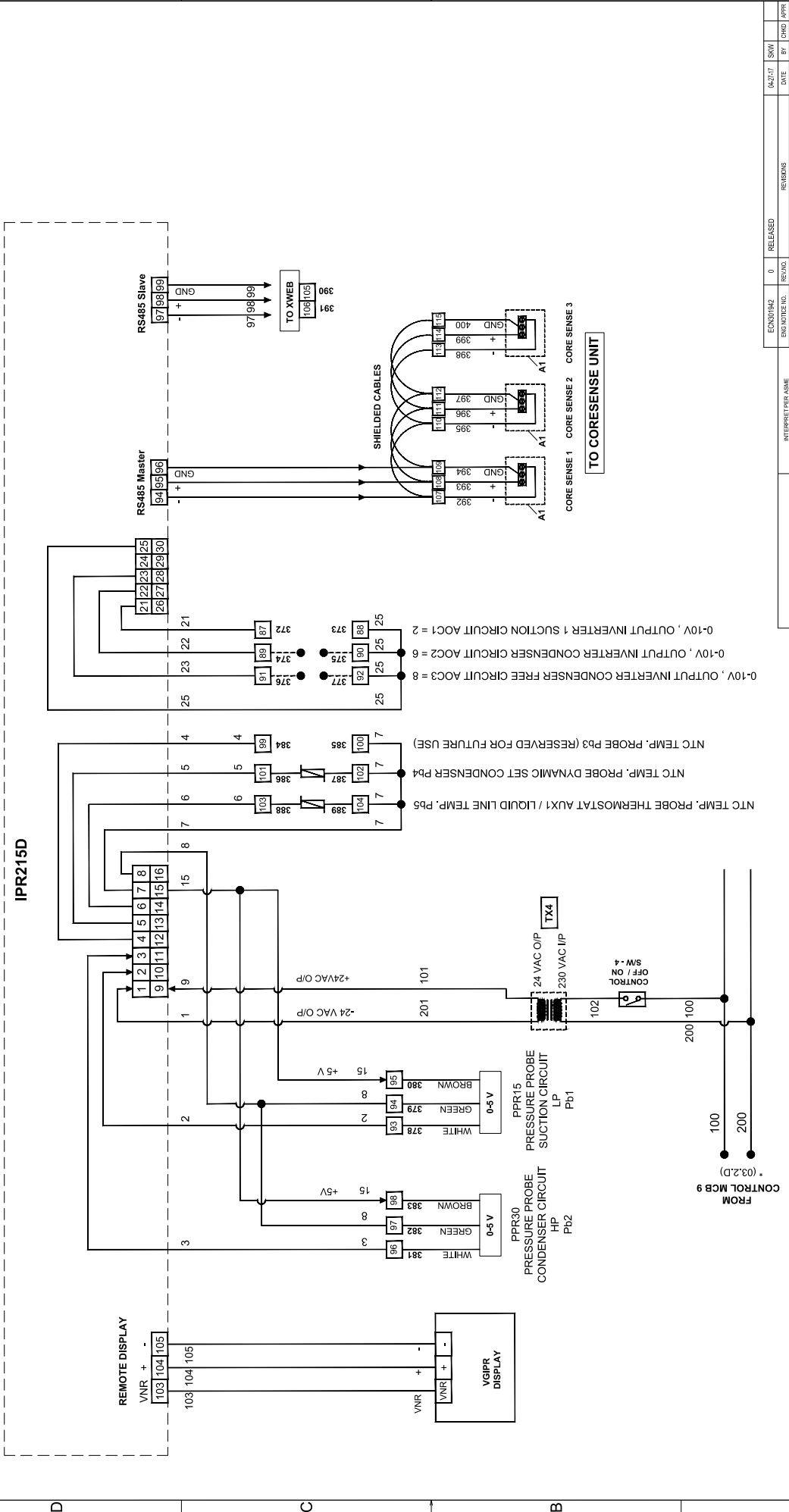

ECN/ISSUE NO.	RELEASED	REVISIONS	DATE	BY	CHKD	APPR
36	0		04-27-17	SKW		

CONFIDENTIALITY NOTICE
 THIS DRAWING AND INFORMATION CONTAINED HEREIN ARE THE EXCLUSIVE PROPERTY OF COPELAND LP. NO PART OF THIS DRAWING OR INFORMATION IS TO BE REPRODUCED, COPIED, OR TRANSMITTED IN ANY FORM OR BY ANY MEANS, ELECTRONIC OR MECHANICAL, INCLUDING PHOTOCOPYING, RECORDING, OR BY ANY INFORMATION STORAGE AND RETRIEVAL SYSTEM, WITHOUT THE WRITTEN CONSENT OF COPELAND LP.

MATERIAL SPECIFICATION

REVISED BY	DATE	SCALE	DATE FORWART.
SKW	04-27-17		MM.DD.YY

TITLE
 DIAGRAM-WIRING 3C 60HZ

DRAWING NUMBER
 SHEET 4 OF 12

UNCONTROLLED COPY - DO NOT MODIFY

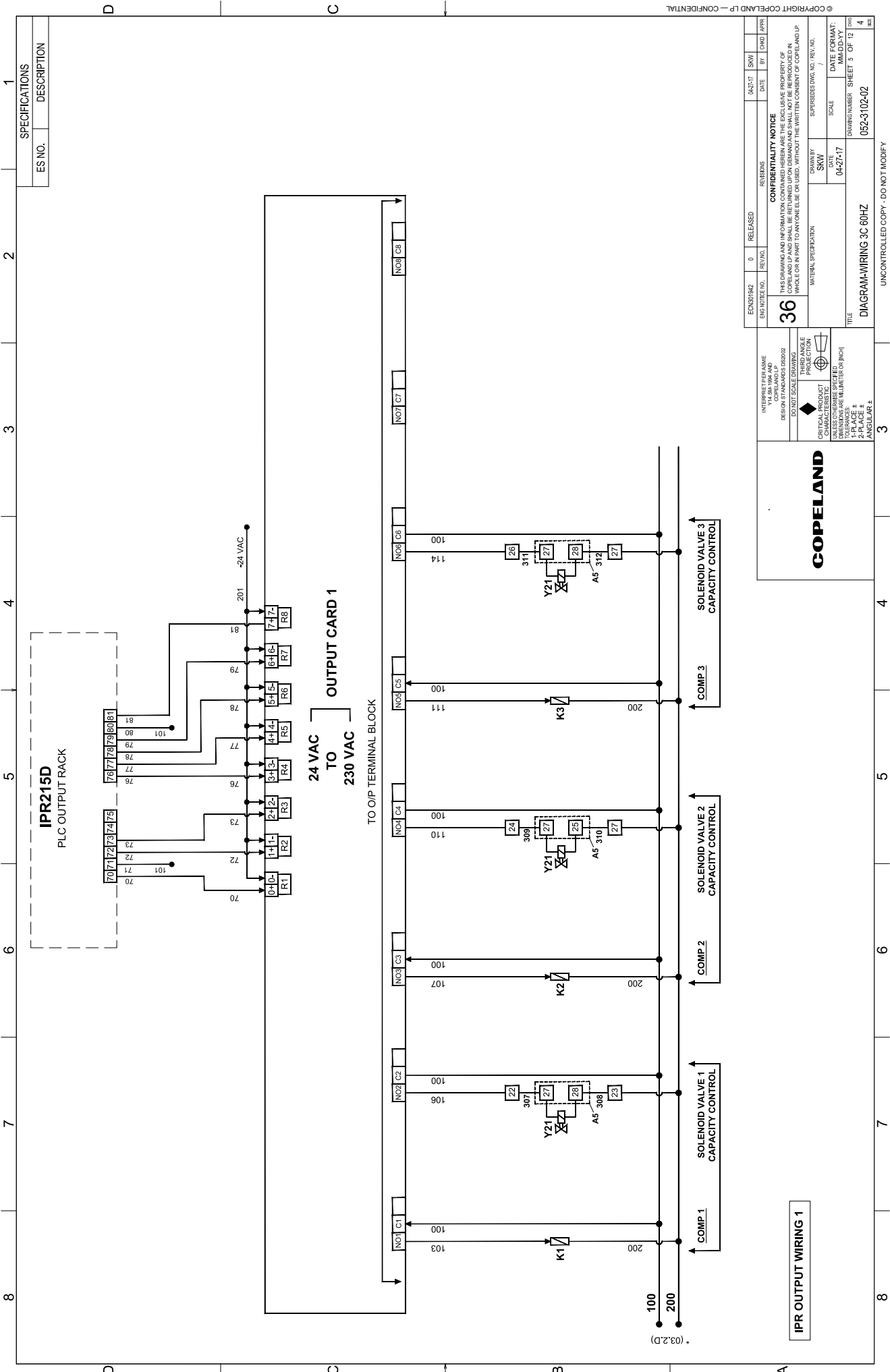

© COPYRIGHT COPELAND LP - CONFIDENTIAL

SPECIFICATIONS	
ES NO.	DESCRIPTION

ECN001942	0	RELEASED	REVISIONS	DATE	BY	CHKD	APPR
36							
<p>CONFIDENTIALITY NOTICE THIS DRAWING AND INFORMATION CONTAINED HEREIN ARE THE EXCLUSIVE PROPERTY OF COPELAND LP. IT IS TO BE KEPT IN CONFIDENTIALITY AND NOT REPRODUCED, COPIED, OR TRANSMITTED IN ANY MANNER WITHOUT THE WRITTEN CONSENT OF COPELAND LP.</p>							
MATERIAL SPECIFICATION				DRAWN BY			
SUPERSEDES ENG. NO. / REV. NO.				SCALE			
DATE OF DRAWING				DRAWING NUMBER			
SHEET 5 OF 12				SHEET 5 OF 12			
TITLE				052-3102-02			
DIAGRAM-WIRING 3C 60HZ							
UNCONTROLLED COPY - DO NOT MODIFY							

COPELAND

INTERPRET PER ASME Y14.5M-1994 AND DESIGN TO STANDARDS ISO9002
 DO NOT SCALE DRAWINGS

CRITICAL PRODUCT CHARACTERISTICS

UNLESS OTHERWISE SPECIFIED:
 DIMENSIONS ARE IN INCHES
 TOLERANCES: FRACTIONS: ± 0.001 (1/1000)
 DECIMALS: ± 0.001 (1/1000)
 ANGULAR: ± 0.001 (1/1000)

IPR OUTPUT WIRING 1

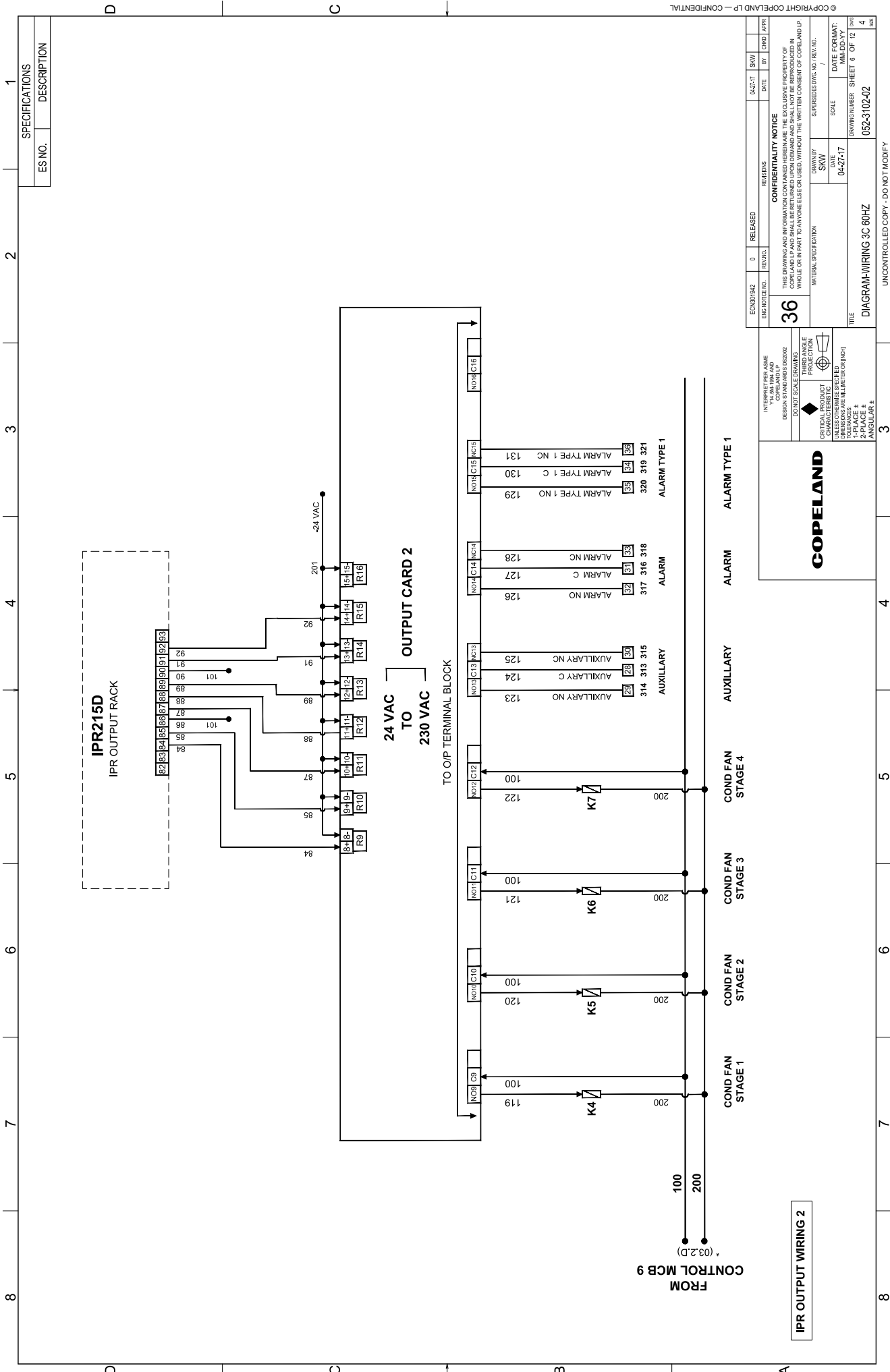

ENGINEERING NO.	0	RELEASED	REVISIONS	DATE	BY	CHKD	APPR	
36								
<p>CONFIDENTIALITY NOTICE THIS DRAWING AND ITS CONTENTS ARE THE PROPERTY OF COPELAND LP AND SHALL BE RETURNED UPON DEMAND AND SHALL NOT BE REPRODUCED IN WHOLE OR IN PART TO ANYONE ELSE OR USED, WITHOUT THE WRITTEN CONSENT OF COPELAND LP.</p> <p>MATERIAL SPECIFICATION: _____ DRAWN BY: SKW / _____ DATE: 04-27-17 SCALE: _____ SUPPERSERIES DWG. NO. / REV. NO.: _____ DATE FORMAT: MM-DD-YY</p>								
TITLE				DRAWING NUMBER				SHEET 6 OF 12
DIAGRAM-WIRING 3C 60HZ				052-3102-02				4
UNCONTROLLED COPY - DO NOT MODIFY								

COPELAND

INTERPRET PER ASME DESIGN STANDARDS D2002
 COPELAND LP
 PROJECTION
 CRITICAL PRODUCT CHARACTERISTICS
 DIMENSIONS ARE MILLIMETER OR (INCH)
 1-PLACE ±
 2-PLACE ±
 ANGULAR ±

IPR OUTPUT WIRING 2

FROM CONTROL MCB 9
 * (03.2.D)

IPR215D
 IPR OUTPUT RACK

24 VAC TO
 230 VAC
 OUTPUT CARD 2

TO OIP TERMINAL BLOCK

ES NO.	DESCRIPTION
1	SPECIFICATIONS

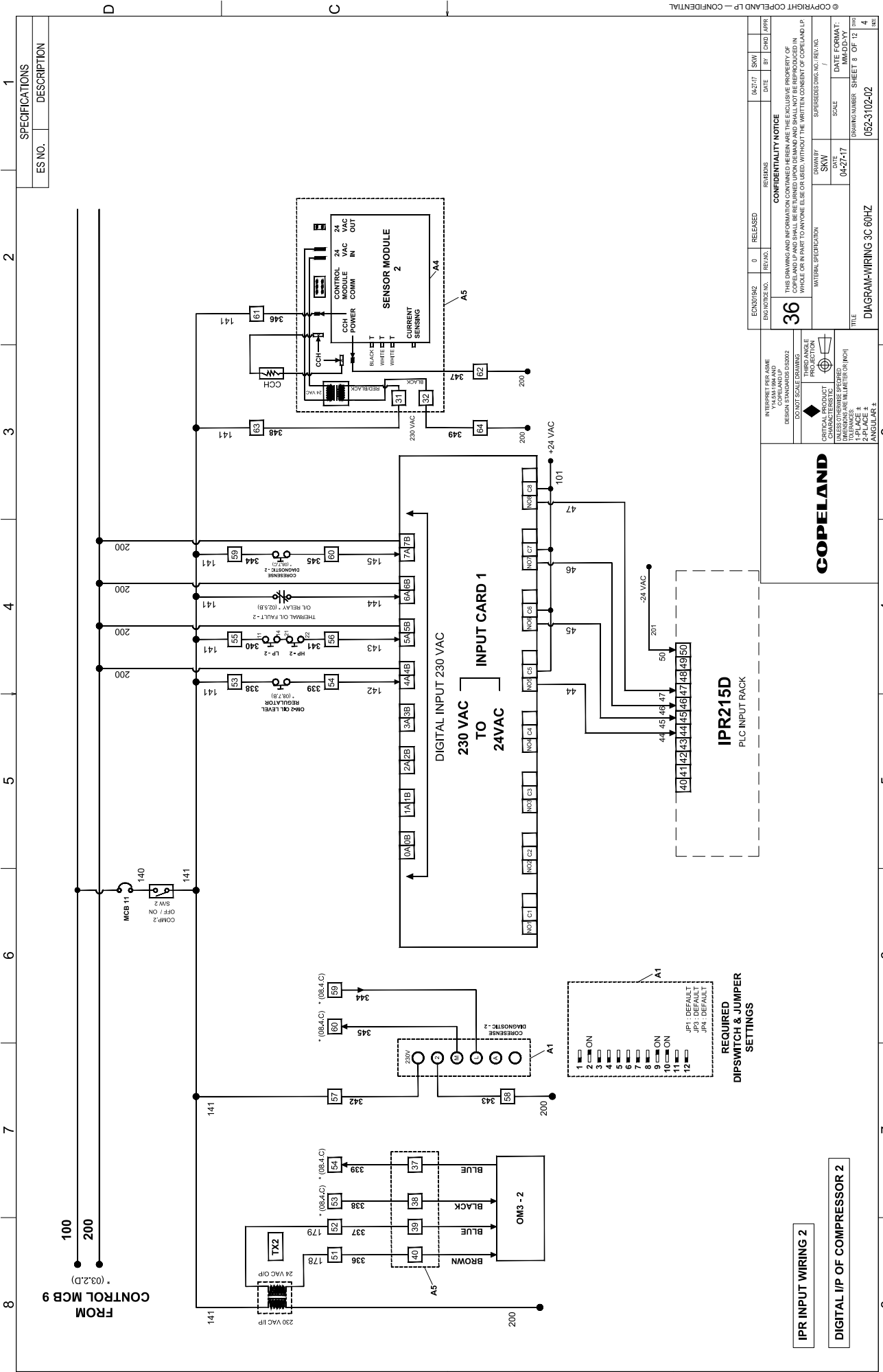

ES NO.	DESCRIPTION
1	SPECIFICATIONS

ENGINEER NO.	REVISED	RELEASED	REVISIONS	DATE	BY	CHKD	APPR
EQ021942	0			04-27-17	SKW		

CONFIDENTIALITY NOTICE

THIS DRAWING AND INFORMATION CONTAINED HEREIN ARE UNCLASSIFIED EXCEPT WHERE SHOWN OTHERWISE. IT IS THE PROPERTY OF COPPELLAND LP. NO PART OF THIS DRAWING OR INFORMATION IS TO BE REPRODUCED, COPIED, OR TRANSMITTED IN ANY FORM OR BY ANY MEANS, ELECTRONIC OR MECHANICAL, INCLUDING PHOTOCOPYING, RECORDING, OR BY ANY INFORMATION STORAGE AND RETRIEVAL SYSTEM, WITHOUT THE WRITTEN CONSENT OF COPPELLAND LP.

36

MATERIAL SPECIFICATION

DRAWN BY: SKW
DATE: 04-27-17

SCALE: /

DATE FORMAT: MM-DD-YY

DRAWING NUMBER: 052-3102-02

SHEET 8 OF 12

TITLE: DIAGRAM-WIRING 3C 60HZ

UNCONTROLLED COPY - DO NOT MODIFY

INTERPRET PER NAME
COPPELLAND LP

DESIGN STANDARDS 030002

DO NOT SCALE DRAWINGS

PROTECTION

CRITICAL PRODUCT

UNLESS OTHERWISE SPECIFIED
DIMENSIONS ARE MILLIMETER (OR INCH)
ANGULAR ±

COPELAND

10. Next gen CoreSense

CoreSense is an ingredient brand name for compressor electronics associated with Copeland branded compressors. The CoreSense technology uses the compressor as a sensor to unlock information from within the compressor, providing value-added features such as advanced motor protection, diagnostics, power consumption measurement and communication.

With active protection, advanced algorithms, and features like fault history and LED indicators, the next generation CoreSense (or next gen CoreSense) for Copeland brand compressors enables technicians to diagnose the past and recent state of the system, allowing for quicker, more accurate diagnostics and less downtime. Next gen CoreSense is available as standard with the 4- and 6-cylinder Stream compressors.

The advantages of the next gen CoreSense module versus other protection modules are the response speed and the overall protection scheme. All protection features are functional right after compressor start and the module will stop the compressor.

Basic features	
Motor overheat protection	High discharge temperature protection
Insufficient oil pressure protection	Oil level protection (OM3)
Current protection	Phase failure protection
Power consumption measurement	Under/over voltage protection
Crankcase heater control	Part winding protection
Switching frequency overstepping protection	Connection with computer
LEDs on terminal box cover	Reset button for manual reset

a. Warnings, trips and lockouts

Next gen CoreSense provides 3 different protection levels. Each of them has its own LED colour.

- Warning alarms: compressor will continue to run.
- Trip alarms: compressor turns off for defined time with automatic reset. If the compressor was stopped due to a fault condition, the compressor will restart when the fault condition is cleared and the defined off time has elapsed.
- Lockout alarms: compressor turns off, manual reset is necessary. If the compressor was stopped due to a fault condition, the compressor will restart when the fault condition is cleared and a manual reset using the reset button has been done. If a Modbus extension module is mounted, the reset can be done via Modbus.

b. Oil pressure protection

The next gen CoreSense module receives an input from the oil pressure differential sensor (OPS3) located in the oil pump. The module will issue a warning when the oil pressure differential falls below 0.95 bar for 4 seconds. Once the oil pressure differential falls below 0.95 bar for more than 2 minutes, the module will trip the compressor and a “low oil pressure lockout” will be reported. Before using the reset button, troubleshooting needs to be done to understand the failure. The compressor will switch ON once the CoreSense is manually reset.

c. Oil level protection

The oil protection is achieved with an OM3 level monitoring device. The OM3 uses a hall sensor to measure the oil level. A magnetic float (unaffected by foaming oil) changes its position according to the oil level. The hall sensor converts the magnetic field changes into an equivalent signal, which is used by the integrated electronic controller to monitor and display the actual oil level with LEDs.

OM3 oil protection device



Site glass level control zones

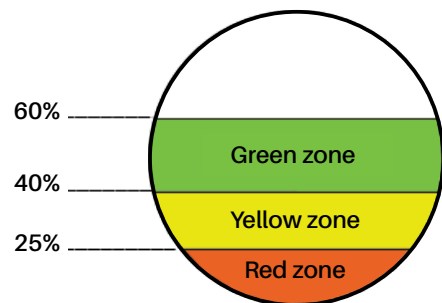

LEDs	Status	Function
●	Oil level in green zone (60 – 40%)	OK
● ●	Oil level in green zone (60 – 40%)	OK
●	Oil level in yellow zone (40 – 25%)	OK
●	Oil level in red zone (25 – 0%)	Warning or trip

d. Motor overheat protection

By using Positive Temperature Coefficient (PTC) thermistors on 4M* and 6M* Stream compressor models, next gen CoreSense provides motor overheating protection.

Two chains of three thermistors each connected in series are embedded in the motor windings

Static overheat protection

The next gen CoreSense module will trip the compressor if the motor windings are getting too hot.

- Standard condition:
Total resistance of the thermistor chains @ 25 °C ≤ 1.8 kΩ
- Alarm condition:
Trip condition: PTC resistance > 4.5 kΩ;
Reset condition: PTC resistance < 2.75 kΩ; 5 min time delay.
- Trip due to sensor failure:
Short circuit: PTC resistance < 20 Ω;
Open circuit: PTC resistance > 20 kΩ. 5

Dynamic overheat protection

If the motor winding temperature increases in a short period (>240ohm/400ms), the module will trip the compressor. The compressor will restart after 5 minutes.

High discharge temperature protection

Discharge temperature protection is provided using a PT1000 sensor in the compressor cylinder head.

The sensor is pre-installed at the factory and connected to the next gen CoreSense module. The module will protect the compressor from high discharge temperature conditions. If the temperature sensor detects a discharge temperature higher than 154 °C, the module will shut off the compressor until the temperature cools down to an acceptable level (20 K below set point).

The configurable range of trip settings is 108 °C to 154 °C and the reset value is 83 °C to 134 °C.

- Trip value ≥ 154 °C for 0.5 sec
- Trip alarm: automatic reset after 2 minutes; discharge temp < 130 °C

PT1000 sensor technical data:

- Measuring range: -40°C to 155°C, 170°C for 30 minutes max
- Tightening torque: 15 Nm , Protection class: IP65



Discharge temperature sensor

e. Current protection

A current sensor is located in the terminal box.

One power supply wire (2 from the same phase in case of part-winding) is going through this sensor. The direction of the leads has to be respected



Current sensor

f. Locked rotor protection

If, 2.5 seconds after compressor start, the current is 150% of the MOC value, an alarm is triggered and the compressor trips. The alarm is reset after 5 minutes.

After 10 trips, a lockout is activated and the next gen CoreSense module must be reset manually using the reset button (no automatic reset).

g. MOC protection

The MOC value of a compressor is stored into the next gen CoreSense module. The compressor trips if the measured current is higher than the MOC for more than 2 seconds.

This function starts 4.5 seconds after compressor start and resets automatically 5 minutes after tripping.

h. Switching frequency overstepping protection

The number of compressor starts is monitored over a defined period of time. If the compressor reaches the maximum number of starts in a time shorter than the defined one, an alarm is triggered.

Default setting is 10 starts in 1 hour and trip generation.

The reset time is calculated as the difference between the defined time period (1 hour) and the actual time it took for the defined maximum number of starts (10) to occur.

Example:

- 10 starts occurred in 35 minutes
- Alarm is triggered at 35 minutes
- Automatic reset will be done after 25 minutes. It is possible to choose between a warning or compressor trip.

i. MOC detection at first start

Most compressors have two sets of nominal voltages and frequencies:

- 50 Hz or 60 Hz value for part-winding motors (AW...)
- Different voltages for Δ /Y start motors (EW...)

At first start and at every power reset, the next gen CoreSense module automatically detects the compressor power supply (voltage and frequency) and will automatically select the corresponding MOC and undervoltage/overvoltage protection setpoints.

If the measured voltage and/or frequency is different from the one defined on the nameplate, the module will generate a warning.

For example, if an AWM/D (400 V / 50 Hz or 460 V / 60 Hz) motor is connected to a 230 V power line, the green LED will flash.

j. Phase / voltage monitoring

There are 6 voltage sensor circuits to measure the 3 phases. Thanks to the 6 sensors, the part-winding motors can also be protected. The status of each phase in direct on-line and part-winding is monitored for undervoltage, overvoltage and phase asymmetry.

Missing phase protection / Phase failure protection

A comparison is made between the voltage of each phase and their average. If any of the 3 power phases is missing after compressor start, a single-phasing condition exists.

Any voltage imbalance above 60 % is a condition for phase-loss trip.

Alarm conditions: occurs in case of missing phase conditions.

Trip time: 5 minutes with automatic reset.

A missing phase can be detected during start-up and when the compressor is running.

Undervoltage protection

Occurs when the compressor voltage is lower than the nominal supply voltage.

Low voltage warning condition: voltage < 85 % of the nominal line voltage for 2 seconds. Low voltage trip conditions: voltage < 75 % of the nominal line voltage 2 seconds.

Trip time: 2 minutes.

Overvoltage protection

Occurs when the compressor voltage is higher than the nominal supply voltage.

High voltage warning condition: voltage > 115 % of the nominal line voltage for 2 seconds. High voltage trip conditions: voltage > 125 % of the nominal line voltage for 2 seconds.

Trip time: 2 minutes.

Voltage imbalance protection

The purpose of this feature is to protect the compressor against a voltage imbalance that could lead to motor overheating.

A configurable setting (default = 5 %) for voltage imbalance is used to determine the operating limit of the compressor. The voltage imbalance setting is configurable in the range of 2 to 8 % using the next gen CoreSense module app.

Alarm conditions:

- Warning: when the voltage imbalance > 3 % (configurable).
- Trip: when the voltage imbalance > 5 % (configurable).
- Reset: automatic reset after 5 min; voltage imbalance < 5 %.

Part-winding protection

The two winding supply cables should go through the current sensor in the same direction. At first start or at power reset of the next gen CoreSense module, the voltage is measured on both windings.

If the voltages are identical:

- Compressor is connected in full winding, the protection is disabled.
- If the voltages are different, the voltages are compared again after 1 second.
- If the voltage on the second winding is the same as on the first winding, the compressor is connected in part-winding and the protection is enabled.
- If the voltage on the second winding is not the same as on the first winding, the second winding is improperly connected and the compressor trips.

The user has the possibility to select between a warning or trip condition. After a trip, the compressor will restart after 2 minutes. Default setting is trip.

k. LEDs on the terminal box cover

Status LEDs in 3 colours (green, orange and red) are visible on the top of the T-box.



- Compressor status codes

- Steady green: An indication of normal operation. There are no faults or issues with the compressor.
- Flashing green: An indication that there is a warning condition. The compressor keeps running.
- Steady orange: An indication that the compressor is in emergency mode.
- Flashing orange: An indication that the compressor has tripped and will automatically restart after a defined time (auto reset).
- Steady red: An indication that CoreSense is in parametrization mode.
- Flashing red: An indication that the compressor is locked out. Manual reset is needed for restart.

Failure alarms displayed by LEDs

Alarms are displayed via colored LEDs and flashing sequences. Every flash sequence is interrupted by a 2-second pause.

Chap	Flash code	Protection feature	Standard delivery	Standard settings			
				Compressor keeps running Warning	Automatic reset Trip	Manual reset required Lockout	Automatic reset after trip
5.1.1	1	Low oil pressure (oil pump)	X	< 0.95 bar after 4 sec		< 0.95 bar after 2 min	
5.1.2		Oil level protection (OM)	X	Selection possible	Oil level below 25 %		Correct oil level
5.2.1	2	Static motor overheat protection	X		PTC resistance > 4.5 kΩ		5 minutes and PTC resistance < 2.75kΩ
5.2.2		Dynamic motor overheat protection	X		> 240 Ω/400 ms		5 minutes
5.3	3	High discharge temperature (DLT)	X		154 °C		2 minutes and < 130 °C
5.4.1	4	Locked rotor protection	X		150 % of MOC	10 X Trip	5 minutes
5.4.2		Maximum operating current (MOC)	X		MOC		5 minutes
5.4.3		Switching frequency protection	X	Selection possible	10 starts/hour		When number of starts/set time period is lower than set value
5.4.4		MOC detection at first start	X	Voltage different from nameplate			
5.5.1	5	Missing phase protection	X		60 % of voltage imbalance		5 minutes
5.5.2		Undervoltage protection	X	< 85 % of nominal voltage for 2 sec	< 75 % of nominal voltage for 2 sec		2 minutes
5.5.3		Oversvoltage protection	X	> 115 % of nominal voltage for 2 sec	> 125 % of nominal voltage for 2 sec		2 minutes
5.5.4		Voltage imbalance protection	X	Imbalance > 3 %	Imbalance > 5 %		5 minutes and min 2 % below setpoint
5.5.5		Welded contactor protection	X	No demand signal/current on one phase	Selection possible	10 X Trip	
5.5.6		Part-winding protection	X	Selection possible	Voltage difference after 1 sec		

Table 4: Flashing explanation **X** = Disabled in standard delivery

I. Alarm history

The 20 most recent alarms are stored in the module memory and can be downloaded with the next gen CoreSense module app.

m. Reset button

Pressing the reset button is needed after a compressor lockout. In addition, it can be used for an immediate trip reset (no compressor waiting time to restart).

- If the tripping condition is cleared, all tripping counters are set to zero, and the compressor can restart.
- If the tripping condition is not cleared, the reset signal is ignored.

n. CoreSense location

The next gen CoreSense module is located in the compressor terminal box. It is prewired to the oil pressure sensor (for compressors with oil pump), the motor thermistor chain (PTC), the discharge temperature sensor and the current sensor.

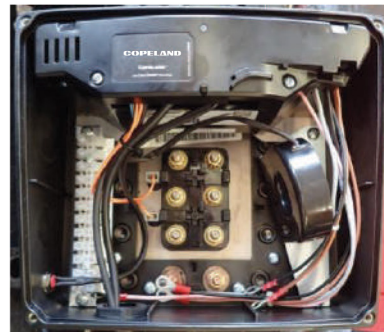

T-box internal view stream-N

Part-winding motors can be connected direct-on-line or part-winding start.

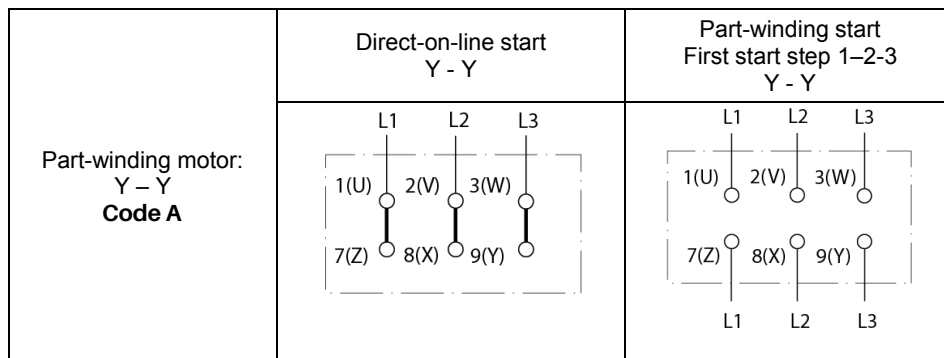

Star / Delta motors can be connected direct-on-line or Star / Delta start.

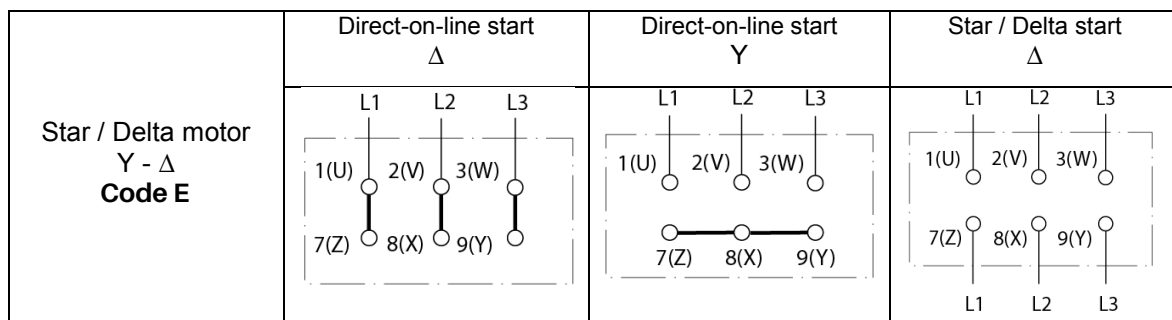

o. Electrical connections

Basic connections

052-3307-00 rev. 1

SEE ENCLOSURE
052-3307-00

4/6 COMPRESSOR & CO2 (4MTL-35/40/50)

Y-PART WINDING START (AWM/D-N, AWR-N, AWY-N AWC-N, AWX-N)

NG CORESENSE MODULES, TERMINALS			
MODULE	TERMINAL	FUNCTION	
BASIC	1, 2	MODULE POWER SUPPLY	
	3, 4	OIL HEATER	
	5, 6	MOTOR PTC	
	7, 8	DISCHARGE GAS SENSOR	
	9, 10	CURRENT SENSOR	
	11, 12	OPS3	
	13, 14	RESET BUTTON	
	15, 16	DIGITAL OIL LEVEL INPUT FROM TRAXOL	
	17, 18	DEMAND SIGNAL	
	19, 20.	ALARM RELAY (OPEN WHEN ALARM)	
	19, 21.	ALARM RELAY (CLOSE WHEN ALARM)	
	U1, V1, W1	PHASE MONITORING 1, 2, 3.	
	U2, V2, W2.	PHASE MONITORING 7, 8, 9.	
	FE	FUNCTIONAL EARTH	
	DP	DIAGNOSE PORT	
	A	-	BLUETOOTH DATA LOGGER
		-	REAL TIME CLOCK
	B	B1, B2, B3.	SUCTION PRESSURE SENSOR
		B4, B5, B6.	DISCHARGE PRESSURE SENSOR
		B7, B8.	SUCTION TEMPERATURE
C	C1, C2.	HEAD FAN	
	C2, C3.	LIQUID INJECTION	
D	D1, D2.	UNLOADED START	
	D2, D3.	DIGITAL CONTROL	
D4, D6.		DEMAND INPUT	
	E1, E2, E3.	MODBUS	
E4, E5, E6.			

MOTOR TERMINAL-BRIDGES CONFIGURATION

Y-PART WINDING START

YY-DIRECT START

NG CORESENSE DIAGNOSE LED FLASH CODES	
NUMBER OF FLASHING	FAILURE GROUP
1	OIL PROTECTION
2	MOTOR TEMPERATURE
3	DLT MONITORING
4	CURRENT MONITORING
5	PHASE MONITORING
6	ENVELOPE MONITORING

Part Winding Motors (AW...)

Star/Delta Motors (EW...)

2021/MEA/70. Compressor pack installation and operation manual.

28

11. Overall dimension/weight: example 3&4 compressor rack

Model name	EMP -46M160MM-700	EMP -34M099MM-700
Compressor	6MI1-40X-AWM/D-D	4MJ1 -33X-AWM/D-D
Nominal weight	2000 KG	1600 KG
Nominal dimensions (LXWXH) *mm	3775 X 1250 X 1950	3075 X 1250 X 1950
Packed dimensions (LXWXH) *mm	3900 X 1720 X 2300	3300 X 1720 X 2300

12. Installation

Copeland multi-compressor packs are designed exclusively for indoor use. We recommend the compressor pack to be placed preferably within a designated plant equipment room with enough space clearance and adequate ventilation.

- Ensure multi-compressor pack remains within its wooden crate until it's placed in a designated area within the plant room.

Lifting

- a. Multi-compressor pack should only be lifted from the base.
 - b. If using forklift, ensure capacity is correct to lift the pack.
 - c. For crane lifts, attach lifting straps to the four corners of the frame base and evenly distribute to ensure a perpendicular lift.
- Compressor pack should be located appropriately for easily serviceability. The minimum clearance around the units to be maintained.
 - Designated plant room floor area must allow for the pack weight and size and conform to current building codes.
 - The unit must be set on a flat and level foundation. A single piece concrete slab with footings extending approximately six inches above ground level provides a suitable base.
 - A safe and free working space surrounding 360° to be provided including free access to work on compressor pack conforming to current building codes.
 - If the pack is installed in a plant room, adequate ventilation air must be provided to avoid an excessive temperature rise in the room.

Electrical

- a. All electrical work must be done in accordance with the National Electrical Code and existing local codes.
- b. Power supply must be the same as specified on the unit name plate.
- c. Voltage protection relay is included in the control panel. However, voltage fluctuations in excess of 10 percent must be corrected.
- d. Overload relays are selected in accordance with specified limits, and they must not be changed in size or shorted-out.
- e. Before starting the pack, ensure that all switchgear and motor-protective devices are in place and that all wiring is secure. A complete wiring diagram for troubleshooting the unit will be found inside the control panel cover.

Piping

- a. Proper size refrigeration lines are essential for good refrigeration performance. Suction lines sizes are more critical than liquid or discharge line sizes.
- b. Oversized suction lines may prevent proper oil return to the compressor.
- c. Undersized lines can reduce refrigeration capacity and increase operating cost.
- d. Use only refrigeration grade copper tubing, properly sealed against contamination.
- e. Suction lines should slope 1/4" per 10 feet towards the compressor.
- f. Discharge lines should slope 1/4" per 20 feet toward the condenser.

Refrigerant line insulation

- a. Insulate suction lines from the evaporators to the compressor pack with minimum 1" thickness closed-cell type insulation on low temperature circuits.
- b. Long liquid lines run in areas exposed to high temperatures should be fully insulated with minimum 1/2" insulation.
- c. Suction and liquid lines should never be taped or soldered together.

Leak check

The success of all the subsequent commissioning depends on a leak free system that is free of contaminants, oxides, and non-condensables and that has been evacuated to a low vacuum and charged with the prescribed refrigerant.

- a. The unit is shipped with a holding charge of dry nitrogen and should be leak free.
- b. Ensure that the test pressure do not exceed the system design pressures.
- c. Do not expose system pressure transducers to test pressures above their design pressure. This can damage the pressure transducer/s.
- d. Do not expose system pressure controls HP/LP, LP or HP to test pressures above their design pressure. This can damage the pressure controls.
- e. Using an approved, calibrated electronic gas leak detector, leak test the entire system. Be sure to pay attention to all joints.
- f. Periodically check functionality of the electronic leak detector during this process.
- g. To further check system integrity, spray a soapy water solution over joints, then visually inspect for bubbles.
- h. Leave the system under pressure for a designated period (24 Hours).
- i. Check and record the ambient temperatures and the system pressure with calibrated approved instruments. This process is to be carried out every 8-12 hours during the pressure testing process.
- j. If the test pressures cannot be maintained, repeat the leak testing process employing the isolation of sections of the system to determine the source of leaks. Repair the leak and repeat the leak testing process until system can be signed off as leak free and approved by authorized personnel.
- k. Record findings and confirm pressure testing process completion.

Evacuation

- a. After the system is leak checked, connect approved dual stage vacuum pumps sized to application with fresh oil to both the low and high side evacuation valves.
- b. Ensure all inline system shut-off valves and solenoid valves are fully open.
- c. Evacuate the system to 300 microns.
- d. A triple evacuation is recommended. The third and final evacuation should achieve a value of 300 microns or less. After this vacuum is reached, system is ready for refrigerant charging and add as much refrigerant as possible into the receiver.

Refrigerant charging

- a. The system should be charged in liquid form, directly into liquid receiver.
- b. Log the amount of refrigerant added to the system and record findings.

Oil charging

- a. Check the oil level within each compressor, viewing the oil level controls oil sight glass.
- b. Pump additional oil into each compressor to a maximum 1/2 sight glass level.
- c. Pump additional oil into the oil separator/reservoir to top of lower sight glass level.

Start up

1. Check and verify manual settings on LP/HP switches.
2. Ensure all service valves and shut-off valves are fully open.
3. Check and verify all controllers are programmed according to the temperature requirement for walk-in-chiller/freezer, cabinets, cases, etc., and liquid line solenoid valves are energized and open.
4. With all switchgear and breakers turned off, including control switches for compressors and condenser fans, apply power to the unit. Switch-on the main incoming breaker alone.
5. A red-light LED on the control panel indicates incorrect voltage. Check with a voltmeter to see if correct voltage is connected to the unit. Correct the power supply before proceeding.
6. Turn on the circuit breakers for the control power. Copeland electronic controller installed on the unit will initiate at this time.
7. Check suction and discharge pressure transducers are assigned to the correct input and verify their readings on the display.
8. Modify/edit program on Copeland controller and set parameters in accordance to the application.
9. Check and verify all safety controls (ensure breakers for power circuit is in off position).
10. Check for the connection of condenser fan motor thermistors in the control panel. If thermistors are not present, add jumper across the terminals (refer page 19 in electrical drawing)

11. Turn-on selector switch and power circuit breaker for condenser fan 1. Verify to see condenser fan motor is running in the correct rotation.
12. Repeat step 11 for remaining condenser fans, one at a time.
13. Turn-on selector switch and power circuit breaker for compressor 1 and check its operation.
14. Repeat step 12 for remaining compressors, one at a time.
15. When each circuit and compressor has been tested, charge appropriate amount of liquid refrigerant on the suction side.
16. Check the refrigerant level in the receiver. The minimum level that should be maintained is 20%.
17. Check the oil reservoir and add oil as necessary. The oil level should be between the upper and lower reservoir sight glass.

System balancing

- a. It's imperative that the system be balanced during the commissioning process.
- b. Ensure that as all refrigeration circuits come online, compressor pack is maintained within its operational envelope.
- c. Ensure that all evaporators are delivering correct superheat and that no flooding back occurs.
- d. Careful monitoring is required at this period of initial operation.
 1. Monitor compressor oil level.
 2. Monitor system pressures.
 3. Monitor current drawn by individual compressors and condenser fans.
 4. Monitor cut-in and cut-off of compressors to verify against short cycling.

13. Compressor pack error codes

Error code	Reason
EAT1	Compressor 1 overload relay trip
EAT2	Compressor 2 overload relay trip
EAT3	Compressor 3 overload relay trip
EAT4	Compressor 4 overload relay trip
EAP1	Compressor 1 LP or HP trip
EAP2	Compressor 2 LP or HP trip
EAP3	Compressor 3 LP or HP trip
EAP4	Compressor 4 LP or HP trip
EAO1	Error in OM3 oil level regulator for compressor 1
EAO2	Error in OM3 oil level regulator for compressor 2
EAO3	Error in OM3 oil level regulator for compressor 3
EAO4	Error in OM3 oil level regulator for compressor 4
Insufficient oil pressure 1L	OPS tripped connected to CoreSense module for compressor 1
Insufficient oil pressure 2L	OPS tripped connected to CoreSense module for compressor 2
Insufficient oil pressure 3L	OPS tripped connected to CoreSense module for compressor 3
Insufficient oil pressure 4L	OPS tripped connected to CoreSense module for compressor 4
LOA1	Overload relay or motor high temp trip for condenser fan 1
LOA2	Overload relay or motor high temp trip for condenser fan 2
LOA3	Overload relay or motor high temp trip for condenser fan 3
LOA4	Overload relay or motor high temp trip for condenser fan 4
Low liquid LED indication	Low liquid level in receiver

14. Commissioning report

A permanent data sheet should be prepared on each installation, with a copy for the owner and the original for the installing contractor. If another firm is to handle service and maintenance, additional copies should be prepared as necessary.

System reference data

The following information should be filled out and signed by the refrigeration installation contractor.

Date system installed: _____ Date started _____

Installer contact details: _____

Job name / location: _____

Compressor pack model: _____

Compressor pack serial no.: _____

Electrical power input: _____

Condenser model: _____ Serial no.: _____

Compressor model / serial no. _____ / _____

Compressor model / serial no. _____ / _____

Compressor model / serial no. _____ / _____

Compressor model / serial no. _____ / _____

Compressor model / serial no. _____ / _____

Refrigerant: _____

Evacuation: # times _____ Final micron: _____

System suction pressure: _____ System discharge pressure: _____

Ambient: _____

Compressor 1 current in amps: L1 _____ / L2 _____ / L3 _____

Compressor 2 current in amps: L1 _____ / L2 _____ / L3 _____

Compressor 3 current in amps: L1 _____ / L2 _____ / L3 _____

Compressor 4 current in amps: L1 _____ / L2 _____ / L3 _____

Compressor 5 current in amps: L1 _____ / L2 _____ / L3 _____

We hereby acknowledge that the compressor pack unit is performing as specified.

Prepared by: _____

Date: _____

Confirmed by: _____

Date: _____



About Copeland

Copeland is a global leader in sustainable heating, cooling, refrigeration and industrial solutions. We help commercial, industrial, refrigeration and residential customers reduce their carbon emissions and improve energy efficiency. We address issues like climate change, growing populations, electricity demands and complex global supply chains with innovations that advance the energy transition, accelerate the adoption of climate friendly low GWP (Global Warming Potential) and natural refrigerants, and safeguard the world's most critical goods through an efficient and sustainable cold chain. We have over 18,000 employees, with feet on the ground in 50 countries - a global presence that makes it possible to serve customers wherever they are in the world and meet challenges with scale and speed. Our industry-leading brands and diversified portfolio deliver innovation and technology proven in over 200 million installations worldwide. Together, we create sustainable solutions that improve lives and protect the planet today and for future generations. For more information, visit [copeland.com](https://www.copeland.com).

Follow us:



To learn more, visit [copeland.com](https://www.copeland.com)

(2021/MEA/70) Compressor pack installation and operation manual
8530148 ©2024 Copeland LP.

COPELAND